



**STANDARD CONSTRUCTION**

BODY:  
30 GAUGE HOT-DIPPED GALVANIZED STEEL SHEET

INSULATION:  
R4.2 OR R6 BLACK DIFFUSER BOARD

OPTIONS:  
FLANGED (R4/R6BF)  
W/ COLLAR (R4/R6MTB)  
W/ GASKET (R4/R6BFG)  
CUSTOM SIZES AVAILABLE

**STANDARD SIZES:**

| W X H   |
|---------|
| 4 X 4   |
| 6 X 4   |
| 6 X 6   |
| 8 X 4   |
| 8 X 6   |
| 8 X 8   |
| 10 X 4  |
| 10 X 6  |
| 10 X 8  |
| 10 X 10 |
| 12 X 6  |
| 12 X 8  |
| 12 X 10 |
| 12 X 12 |
| 14 X 6  |
| 14 X 8  |
| 14 X 14 |
| 16 X 6  |
| 16 X 8  |
| 16 X 16 |

**FEATURES**

DESIGN INCLUDES 1/2" DRYWALL LIP.

OPENING 1/4" OVERSIZED TO ACCOMMODATE REGISTER/GRILLE.

DUAL BEAD BOX DESIGN FOR ADDED STRENGTH.

BLACK DIFFUSER BOARD COATED WITH EPA-REGISTERED, ANTI-MICROBIAL, PROTECTIVE ACRYLIC AGENT ALONG AIR STREAM SIDE.

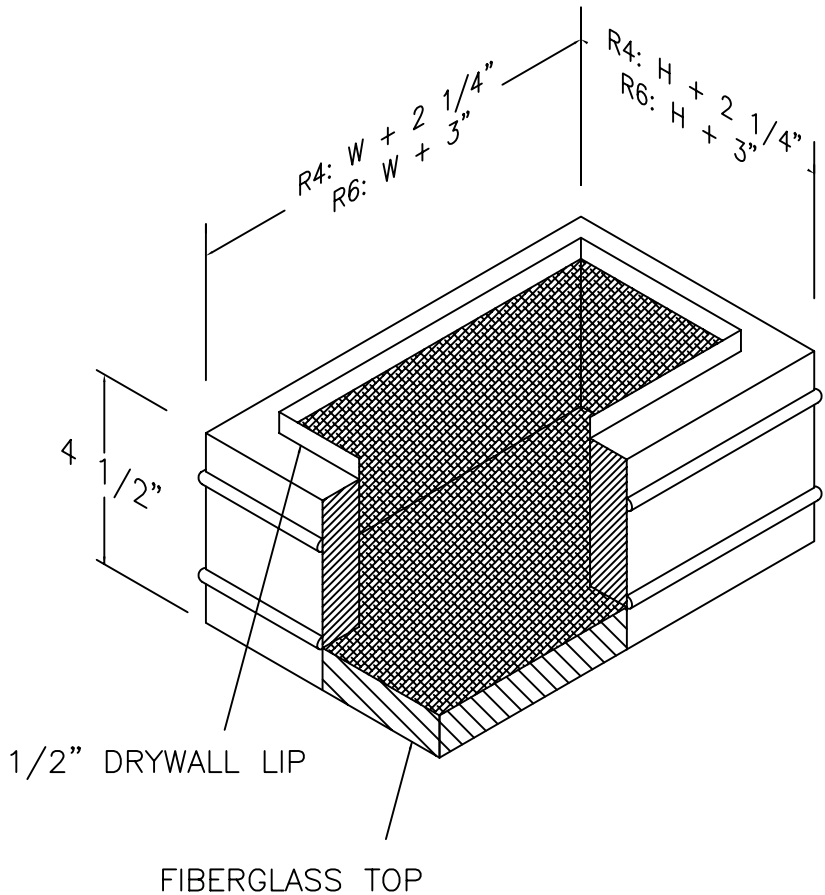

|                                                                                                                                                                                                                         |
|-------------------------------------------------------------------------------------------------------------------------------------------------------------------------------------------------------------------------|
| JOB NAME:                                                                                                                                                                                                               |
| LOCATION:                                                                                                                                                                                                               |
| ARCHITECT:                                                                                                                                                                                                              |
| ENGINEER:                                                                                                                                                                                                               |
| CONTRACTOR:                                                                                                                                                                                                             |
| CONTACT MIAMI TECH INC. FOR ADDITIONAL INFORMATION OR WITH SPECIAL REQUIREMENTS.<br>3611 NW 74TH ST<br>MIAMI, FL 33147<br>PHONE: 305-693-7054 FAX: 305-693-6152<br>WEB: WWW.MIAMITECH.COM<br>EMAIL: SALES@MIAMITECH.COM |

**R4/R6BU**

UNFLANGED REGISTER BOX  
PRODUCT SPECIFICATIONS

NOTE: ALL DRAWINGS SUBJECT TO CHANGE WITHOUT PRIOR NOTICE.



|                |                |                     |                    |
|----------------|----------------|---------------------|--------------------|
| DRAWN BY: JR   | DATE: 07/14/06 | SCALE: NOT TO SCALE | DRAWING NO. R4R6BU |
| CHECKED BY: IG | DATE: 07/14/06 | REVISION: 1         |                    |